

**PHYSICS 2**  
**0580**

**CAMEROON GENERAL CERTIFICATE OF EDUCATION BOARD**  
General Certificate of Education Examination

**JUNE 2019**

**ORDINARY LEVEL**

Subject Title	Physics
Paper No.	2
Subject Code No.	0580

***Two and a half hours***

***Answer ALL questions.***

*Section I is designed to be answered in 1 hour and Section 2 in 1½ hours.*

*You are advised to divide your time accordingly.*

***In section II answer EITHER the a, b and c OR the d, e, and f of each question***

*For your guidance the approximate mark for each part of a question is indicated in brackets.*

*You are reminded of the necessity for good English and orderly presentation in your answers.*

*In calculations you are advised to show all the steps in your working, giving your answer at each stage.*

*Where necessary, assume:*

- the acceleration of free fall,  $g = 10 \text{ m s}^{-2}$*
- the speed of light in air,  $c = 3 \times 10^8 \text{ m s}^{-1}$*
- the charge on an electron,  $e = 1.6 \times 10^{-19} \text{ C}$*

*Calculators are allowed.*

Turn over

**SECTION I**

**Answer all questions in one hour**

1. (a) Figure 1 shows a circuit diagram used to run a small radio from the mains transformer:

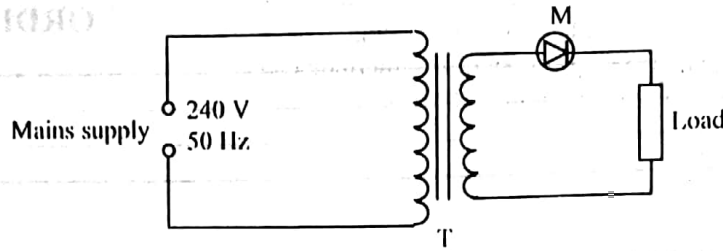

**Figure 1**

- (i) What kind of transformer is used? Explain. (2 marks)
- (ii) Identify the component, M, and state its function. (2 marks)

(b) Figure 2 shows a solenoid wound on a cardboard tube. The ends of the solenoid are connected to a DC source through a rheostat and switch.

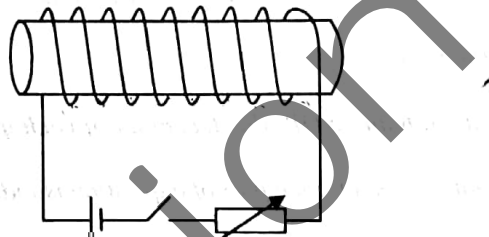

**Figure 2**

- (i) Copy the figure and sketch the magnetic field (indicating its polarity) when the switch is closed. (2 marks)
- (ii) State one method of making the magnetic field stronger. (1 mark)
- (iii) Name one device which makes use of magnetism that can be switched on and off. (1 mark)

2. Figure 3 shows a simple circuit diagram.

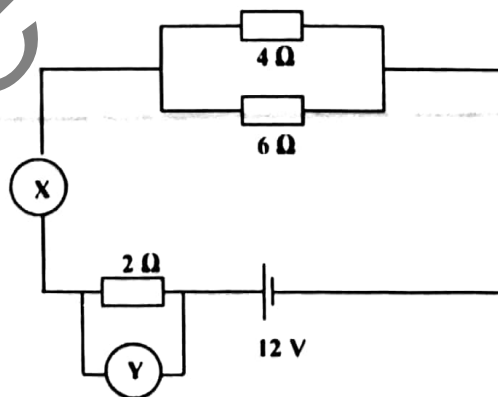

**Figure 3**

- (a) Identify the instruments labelled X and Y. (2 marks)
- (b) Calculate the total resistance of the circuit. (2 marks)
- (c) Calculate the current flowing through the 2 Ω resistor. (2 marks)

3. (a) (i) Define specific latent heat of vaporization. (2 marks)  
 (ii) Why is the specific latent heat of vaporization of water much larger than its specific heat capacity? (2 marks)
- (b) The mercury column of a newly made mercury-in-glass thermometer is 5 cm long when the bulb is dipped in pure melting ice. When the bulb is transferred into steam from pure boiling water at standard atmospheric pressure, the mercury column is 17 cm long. When the bulb is dipped into another liquid of unknown temperature,  $\theta$ , the mercury column is 10 cm long.  
 (i) What is the thermometric property of this thermometer? (1 mark)  
 (ii) Calculate the unknown temperature,  $\theta$ , in  $^{\circ}\text{C}$ . (2 marks)

4. Figure 4 shows a simple pulley system used to raise a load of 500 N unto a storey building under construction by applying an effort of 200 N.

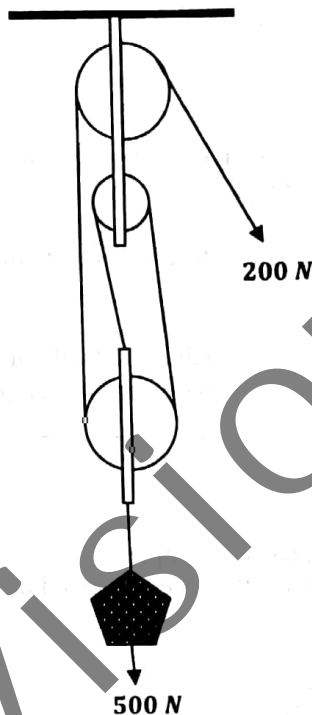

Figure 4

- (a) What is the velocity ratio of the pulley system? (1 mark)  
 (b) Calculate the mechanical advantage of the pulley system. (2 marks)  
 (c) Calculate the efficiency of the pulley system. (2 marks)  
 (d) State two reasons why the efficiency is less than 100%. (2 marks)
5. (a) State the laws of reflection. (2 marks)  
 (b) (i) Draw a ray diagram to show how the eye sees the image of an object in a plane mirror. (3 marks)  
 (ii) State two characteristics of this image. (2 marks)
6. (a) Distinguish between:  
 (i) an intrinsic and an extrinsic semiconductor. (2 marks)  
 (ii) a p-type and an n-type semiconductor. (2 marks)  
 (b) Name an element that can be added to a crystal of pure silicon to produce an n-type semiconductor. (1 mark)

Turn Over

### SECTION II

Answer all questions choosing, EITHER the a, b and c OR the d, e, and f of each question.

Answer EITHER 7a, b and c

7. (a) (i) Define density and state its unit. (2 marks)
- (ii) Describe an experiment to determine the density of a piece of stone (irregularly-shaped object). Include in your description:
- a list of apparatus needed
  - a diagram of the set-up
  - the procedure you will use to collect data
  - how the data is used to obtain the density of the stone
  - any precaution taken to minimize error.
- 5 (6 marks)

- (b) (i) Define pressure. (1 mark)

A rectangular block  $0.01\text{ m}$  by  $0.02\text{ m}$  by  $0.04\text{ m}$  has a mass of  $0.064\text{ kg}$ . Calculate

- (ii) the area of the largest face of the block. (2 marks)
- (iii) the weight of the block. (2 marks)
- (iv) the pressure the block will exert on a surface when lying on its largest face. (2 marks)

- (c) (i) Define elastic limit. (2 marks)

- (ii) A copper wire is stretched by a force which is gradually increased in magnitude until the wire breaks. Sketch a force - extension graph for the wire. On your graph indicate the elastic limit. (3 marks)

OR 7 d, e, and f

7. (d) (i) Define a longitudinal wave and give an example. (2 marks)
- (ii) Describe an experiment to determine the speed of sound in air. Include in your description:
- a list of apparatus needed
  - a diagram of the set-up
  - the procedure you will use to collect data
  - how the data is used to obtain the speed of sound
  - any precaution taken to minimize error.
- (6 marks)

- (e) (i) Define wavelength. (1 mark)

Plane waves generated on the surface of a ripple tank are found to travel  $0.74\text{ m}$  in  $1.6\text{ s}$ . The distance between a crest and an adjacent trough is  $0.06\text{ m}$ . Calculate:

- (ii) The average speed of the wave. (2 marks)
- (iii) The wavelength of the wave. (2 marks)
- (iv) The frequency of the wave. (2 marks)

- (f) (i) Define the principal focus of a converging lens. (2 marks)

- (ii) Draw a ray diagram to show how a converging lens is used as a magnifying glass. (3 marks)

**Answer EITHER 8 a, b and c**

8. (a) (i) State Ohm's law. (2 marks)

In an experiment to verify the relationship between the current,  $I$ , flowing through a conductor, and the potential difference,  $V$ , across its terminals, a student obtained the following data:

V/V	0.0	2.0	4.0	6.0	8.0	10.0	12.0	14.0
I/A	0.0	1.6	3.2	5.0	6.3	7.5	9.4	11.0

(ii) Plot a graph of potential difference,  $V$ , on the y-axis against current,  $I$ , on the x-axis. (5 marks)

(iii) Determine the gradient of the graph and state its significance. (3 marks)

(iv) What is the current in the circuit when the potential difference is 9 V. Show clearly how you arrived at the answer. (2 marks)

(b) (i) Define electric current and state its unit. (2 marks)

(ii) A charge of 40 C flows past a point in a circuit in 10 s. Calculate the current that flows. (2 marks)

(c) (i) Fuses and earth wires are protective devices used in house wiring. State what each of them protects. (2 marks)

(ii) An electric iron is rated 1000 W, 220 V. Determine whether a fuse of value 3.2 A will be suitable for use in the iron. (2 marks)

**OR 8 d, e and f**

8. (d) (i) Define the terms 'fission' and 'fusion' as used in nuclear physics. (2 marks)

The following data was obtained for the radioactive decay of Sodium-24.

Time/hr	0	4	8	12	16	20	24	28
Activity/counts min <sup>-1</sup>	478	395	329	272	226	187	155	140

(ii) Plot a graph of activity on the y-axis against time on the x-axis. (5 marks)

(iii) Use the graph to determine the half-life of Sodium-24. (3 marks)

(iv) What will be the activity of Sodium-24 when the time is 10 hours? Show clearly how you arrived at your answer. (2 marks)

(e) The following equation represents the radioactive decay of Thorium-232 to a different element X.

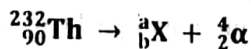

(i) Define radioactive decay. (2 marks)

(ii) Determine the values of  $a$  and  $b$ . (2 marks)

(f) Radioactivity is commonly used in the fields of medicine and industry.

(i) State one use in each of the fields mentioned above. (2 marks)

(ii) State and explain the property of one of the radiations used in (i) above. (2 marks)

0.1333  
3

Answer EITHER 9 a, b and c

9. (a) (i) Define the terms 'speed' and 'velocity'. (2 marks)  
 (ii) When a driver reads the speedometer of his car while the car is moving, what quantity is he reading? (1 mark)  
 (iii) If the speedometer of the car is bad, what can he do to have an idea of the average speed of the car during a journey of a short distance? (3 marks)
- (b) A lorry of mass  $2000 \text{ kg}$  moving along a straight road at a speed  $15 \text{ m s}^{-1}$  has a head-on collision with a car of mass  $1000 \text{ kg}$  travelling in the opposite direction. On collision, both vehicles lock together and come to rest on the spot.  
 (i) Define momentum. (1 mark)  
 (ii) State the law of conservation of linear momentum. (2 marks)  
 (iii) Calculate the momentum of the lorry before the collision. (2 marks)  
 (iv) Calculate the speed of the car before collision. (2 marks)
- (c) A car initially at rest begins to move with a uniform acceleration for  $20 \text{ s}$  until it attains a velocity of  $15 \text{ m s}^{-1}$ .  
 (i) Give the meaning of the underlined phrase. (1 mark)  
 (ii) Calculate the acceleration of the car. (2 marks)  
 (iii) Calculate the distance covered by the car in the  $20 \text{ s}$ . (2 marks)  
 (iv) The driver now applies his brakes to bring the car to rest. State the energy conversion that takes place during the braking process. (2 marks)

OR 9 d, e and f

9. (d) (i) Define the terms 'mass' and 'weight'. (2 marks)  
 (ii) When a butcher uses a beam balance in measuring meat for sale, what physical quantity is he measuring? (1 mark)  
 (iii) The butcher has a beam balance and only one  $1 \text{ kg}$  load. Explain how the butcher can measure  $3 \text{ kg}$  of meat using the balance only two times. (3 marks)
- (e) Musa and Muma sit on opposite sides of a see-saw of negligible weight, and it balances horizontally. Musa has a weight of  $400 \text{ N}$  and sits  $2.7 \text{ m}$  away from the pivot. Muma has a weight of  $300 \text{ N}$  and sits at an unknown distance in the opposite side from the pivot.  
 (i) What do you understand by the 'moment of a force'? (1 mark)  
 (ii) State two conditions that must be fulfilled for the see-saw to balance. (2 marks)  
 (iii) Calculate the moment of Musa about the pivot. (2 marks)  
 (iv) Calculate the distance of Muma from the pivot. (2 marks)
- (f) A girl applies a horizontal force,  $F$ , of  $12 \text{ N}$  to move a box of mass  $20 \text{ kg}$  along the road. Meanwhile there is a constant frictional force of  $4 \text{ N}$  opposing the motion of the box.  
 (i) Define a contact force. (1 mark)  
 (ii) Calculate the resultant force acting on the box. (2 marks)  
 (iii) Calculate the acceleration of the box. (2 marks)  
 (iv) Draw a diagram of the box and indicate with arrow headlines all the forces acting on the box. (2 marks)